

High Voltage Operational Amplifiers PR2201 and PR2202

PR2201 is a monolithic high-voltage operational amplifier with JFET input stage and NPN/PNP output stage.

The wide common mode input range and the large differential input voltage range allow to measure large signals close to the supply lines.

A low quiescent current keeps the heat dissipation low.

PR2202 is a dual operational amplifier based on PR2201.

Features

- Supply voltage up to 80V or $\pm 40V$
- Wide common mode input range
- Near rail-to-rail output
- JFET input stage with very low input bias current
- Output current up to 6mA
- Gain bandwidth product >1 MHz
- Low quiescent current
- Overtemperature shutdown
- Offset compensation by external trimming (only PR2201)

Block Diagram

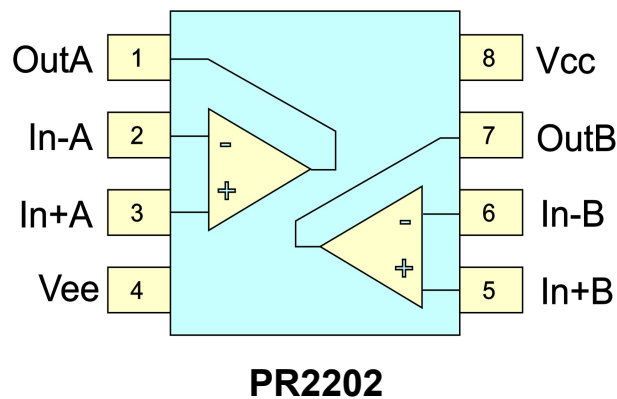
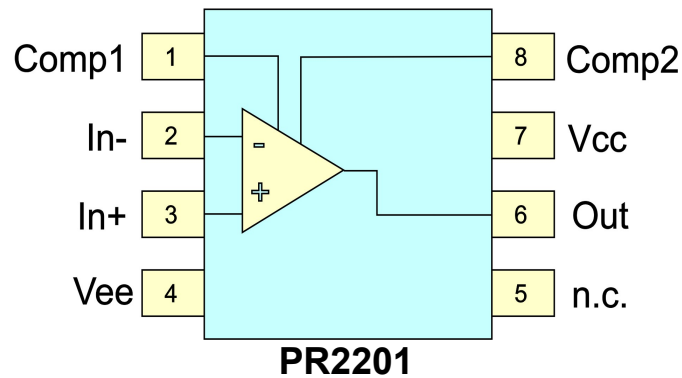

Absolute Maximum Ratings

Parameter	Min	Typ	Max	Units
$V_{CC} - V_{EE}$ (not permanent)	-0.3		90	V
In+, In-	V _{ee}		V _{cc}	V
Storage Temperature Range	-55		150	°C
Electrostatic Discharge (ESD) Protection	1			kV

Electrical Characteristics

$V_{CC} - V_{EE} = 80V$, $T_A = 25^\circ C$, unless otherwise noted.

Parameter	Conditions	Min	Typ	Max	Units
Supply Voltage $V_{CC} - V_{EE}$				80	V
Quiescent current	$V_{OUT} = (V_{CC} - V_{EE})/2$, $I_{OUT} = 0$ for PR2201 (per channel for PR2202)		500	700	μA
Common mode input voltage		$V_{EE} + 1.5V$		$V_{CC} - 2.0V$	
Differential mode input voltage	$V_{IN+} - V_{IN-}$	-60		+60	V
Output voltage		$V_{EE} + 1.0V$		$V_{CC} - 1.0V$	
Output current	$V_{OUT} = V_{EE} + 2V \dots V_{CC} - 2V$	5	6		mA
Input bias current			±5	±100	pA
Common mode rejection ratio		90	120		dB
Supply voltage rejection ratio		85	110		dB
Input offset			±2	±10	mV
Slew rate low => high	$R_L = 500 \Omega$; $G = 1$		0.8		V/μs
Slew rate high => low	$R_L = 500 \Omega$; $G = 1$		1.2		V/μs
Gain bandwidth product	$R_L = 500 \Omega$	1.0			MHz
Open loop gain			n/a		dB
Junction temperature		-20		125	°C
Overtemperature shutdown		140			°C
Thermal resistance Θ_{JA}	SOIC 8L package; still air, free convection		160		°C/W

All data are preliminary

Application Notes

At very high slew rates, especially at the supply voltage, but also at all other pins, integrated circuits can latch, leading to a high current flow and usually fast destruction of the IC and its environment.

Although during IC design precautions were taken to suppress latch-up, this can become critical for high-voltage ICs, especially at voltages above 60V. The slew rate of the supply voltage should be limited e.g. by means of an RC-combination.

All other signals should be blocked by capacitors to avoid sharp transients.

Safety note: Latching circuits can draw very high currents. To avoid consequential damage of the power supply and the danger of fire in case of a failure, it is necessary to limit the current by resistors, active current limiting circuits, or fuses.

Differential voltages in excess to the specified value can damage the input stage.

Note that in a feedback circuit, if at input signals with high slew rates the output cannot follow the input, transients with high differential voltages may occur. This can happen e.g. if the input signal is connected over a bouncing mechanical contact.

If such situations cannot be avoided, the input differential voltage must be limited by an external protection circuit, e.g. fast Zener diodes.

Offset compensation (PR2201 only)

Pins Comp1 and Comp2 allow to compensate the input offset of the amplifier by means of an external potentiometer or two trimmable resistors.

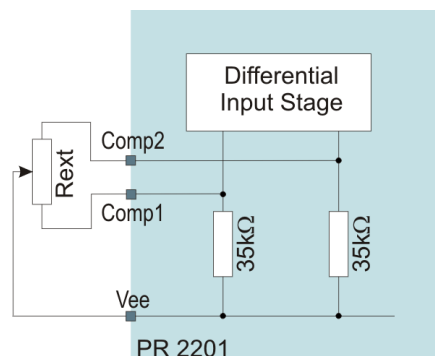

Overtemperature protection

To avoid overheating of the operational amplifiers, there is a built-in overtemperature protection. If this is activated, the output will go to a high-resistance state.

The design of your circuit must consider this situation. E.g. a feedback loop would be opened if the opamp shuts down, which in certain situations may lead to an excess differential input voltage.

The opamp switches on again when the temperature has dropped. This usually leads to intermittent operation until the overload condition is resolved.

Generally, the overtemperature shutdown should be avoided by means of proper thermal design and avoiding overload situations.

Package Dimensions and Designation

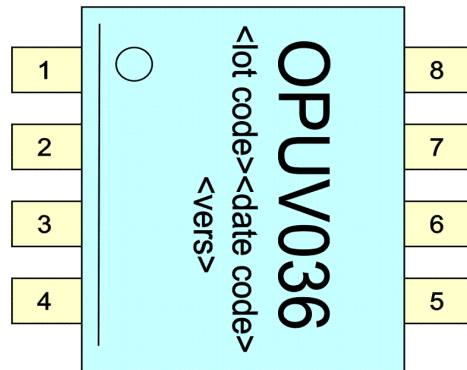

Package: 8L SOIC (150 mils)

Marking:

<vers>: PREMA internal version identifier

<lot code>: PREMA internal lot code

<date code>: date of production (year, week)

PR2202 SOIC package in plastic tube or tape and reel

Packing unit: 100 ICs per tube or 3500 ICs per reel

All parts delivered comply with RoHS. Finish is pure tin.



Disclaimer

Information provided by PREMA is believed to be accurate and correct. However, no responsibility is assumed by PREMA for its use, nor for any infringements of patents or other rights of third parties which may result from its use. PREMA reserves the right at any time without notice to change circuitry and specifications.

Life Support Policy

PREMA Semiconductors products are not authorized for use as critical components in life support devices or systems without the express written approval of PREMA Semiconductor. As used herein:

1. Life support devices or systems are devices or systems which, (a) are intended for surgical implant into the body, or (b) support or sustain life, and whose failure to perform when properly used in accordance with instructions for use provided in the labeling, can be reasonably expected to result in a significant injury to the user.

2. A critical component is any component of a life support device or system whose failure to perform can be reasonably expected to cause the failure of the life support device or system, or to affect its safety or effectiveness.

PREMA Semiconductor GmbH

Robert-Bosch-Str. 6

55129 Mainz Germany

Phone: +49-6131-5062-0

Fax: +49-6131-5062-220

Email: prema@prema.com Web site: www.prema.com