

TA8050P

1.5A MOTOR DRIVER WITH BRAKE FUNCTION

The TA8050P is a 1.5A motor driver which directly drives a bidirectional DC motor. Inputs DI1 and DI2 are combined to select one of forward, reverse, stop, and brake modes. Since the inputs are TTL-compatible, this IC can be controlled directly from a CPU or other control system. The IC also has various protective functions.

FEATURES

- Bidirectional DC motor driver
- Current capacity : 1.5A
- Four modes : Forward, Reverse, Stop, and Brake
- Recommended operating supply voltage range: $V_{CC} = 6V$ to 16V
- Protective functions : Thermal Shutdown, Short Circuit Protection, and Overvoltage Shutdown
- Built-in diode for counteracting counter electromotive force
- Plastic HSIP-7 pin

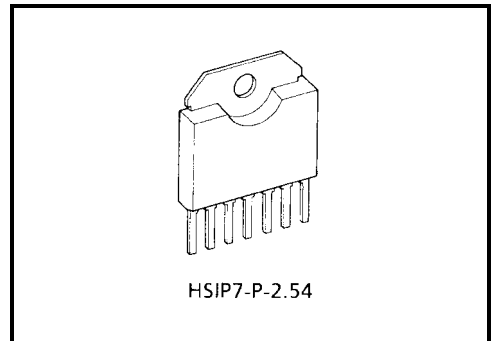

Weight: 1.9 g (typ.)

BLOCK DIAGRAM AND PIN LAYOUT

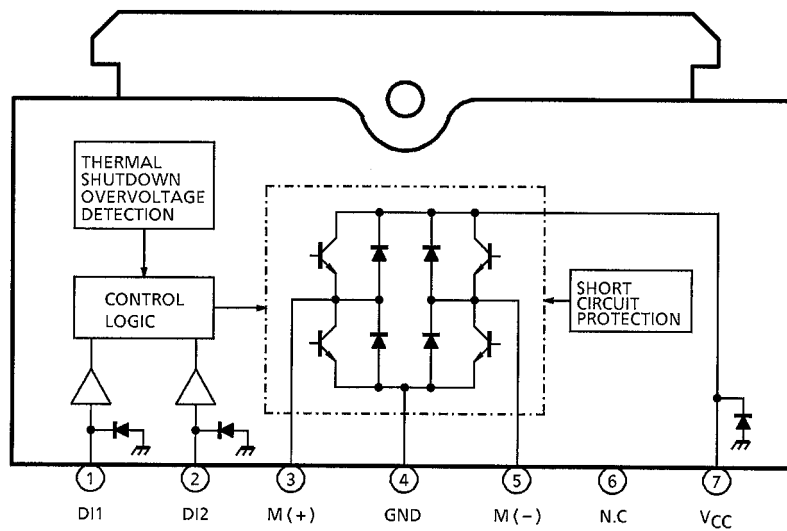

PIN DESCRIPTION

PIN No.	SYMBOL	DESCRIPTION
1 2	DI1 DI2	Output status control pin. Connects to a PNP-type voltage comparator.
3	M (+)	Connects to the DC motor. Both the sink and the source have a current capacity of 1.5A. Diodes for absorbing counter electromotive force are contained on the V _{CC} and GND sides.
4	GND	Grounded
5	M (-)	Connects to the DC motor together with pin 3 and has the same function as pin 3. This pin is controlled by the inputs from pins 1 and 2.
6	NC	Not connected. (Electrically, this pin is completely open.)
7	V _{CC}	Power supply pin. This pin has a function to turn off the output when the applied voltage exceeds 27.5V, thus protecting the IC and the load.

TRUTH TABLE

Input		Output		
DI1	DI2	M (+)	M (-)	
H	H	L	L	(Note)
L	H	L	H	
H	L	H	L	
L	L	OFF (high impedance)		(Note)

Note: Brake mode comes into effect when both M (+) and M (-) go low ; Stop mode comes into effect when both M (+) and M (-) turn OFF.

DESCRIPTION OF MULTI-PROTECTIVE OPERATION

The TA8050P has functions for protection from overvoltage (VSD), overcurrent (ISD), and overheat (TSD). These functions protect the IC (and the motor load in some cases) from deterioration or destruction due to power-related overstress.

The three functions work independently.

Each function is explained below.

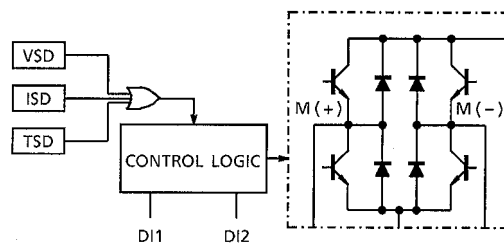

1. Overvoltage protection (VSD)

- Basic operation

When the voltage supplied to the VCC pin is up to the VSD detection voltage, the output is controlled by the input signals. However, when the VCC voltage exceeds the detection voltage, the output enters high-impedance state regardless of the input signals.

- Detailed explanation

The VSD voltage is detected by comparing the Zener voltage with the voltage obtained by dividing VCC with a resistor. When the center voltage of the resistor is higher than the Zener voltage, a transistor-off instruction is issued to the control logic. When it is lower than the Zener voltage, the logic is controlled by the input signals from pins 1 and 2.

2. Overheat protection (TSD)

- Basic operation

When the junction (chip) temperature is up to the TSD detection temperature, the output is controlled by the input signals. When it exceeds the TSD detection temperature, the output enters high-impedance state regardless of the input signals.

- Detailed explanation

The temperature is detected by monitoring V_F of a diode on the chip. When the diode V_F is lower than the internal reference voltage, an output transistor-off instruction is issued to the control logic. When it is higher than the internal reference voltage, the logic is controlled by the input signals from pins 1 and 2.

3. Overcurrent protections (ISD)

- Basic operation

When the output current (pin 3 or 5, I sink or I source) is up to the ISD detection current, the output is controlled by the input signals. When it exceeds the detection current, the output assumes a switching waveform as shown in Fig.1.

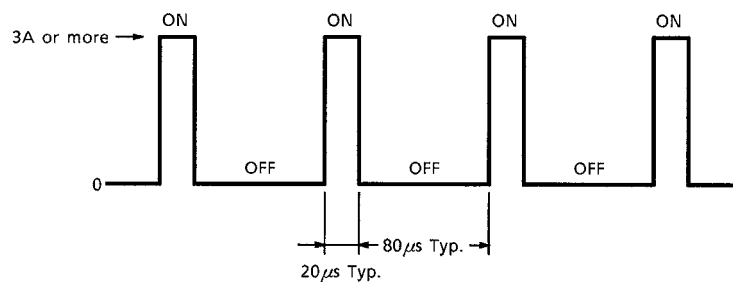

Fig.1 Basic Operation

- Detailed explanation

The output current is detected by monitoring the VBE from each output transistor. One detection circuit connects to one of the output transistors and leads to the short-circuit protection circuit. When a current exceeding the ISD detection current flows through one of the four output transistors, the short-circuit protection circuit is activated. This circuit contains a timer. When overcurrent condition continues for 20 μs (typically), the protection circuit places the output in high-impedance mode and, 80 μs (typically) later, returns the IC to ON mode. The switching-waveform output is repeated until overcurrent condition is no longer present.

MAXIMUM RATINGS (Ta = 25°C)

CHARACTERISTIC	SYMBOL	RATING	UNIT
Supply Voltage	V _{CC}	30	V
	V _{CC}	60 (1s)	
Input Voltage	V _{IN}	-0.3 to V _{CC}	V
Output Current	I _{O-AVE}	1.5	A
Operation Temperature	T _{opr}	-40 to 110	°C
Storage Temperature	T _{stg}	-55 to 150	°C
Power Dissipation	P _D	12.5	W
Lead Temperature Time	T _{sol}	260 (10s)	°C

ELECTRICAL CHARACTERISTICS (V_{CC} = 6 to 16V, T_c = -40 to 110°C)

CHARACTERISTIC	SYMBOL	PIN	TEST CIR-CUIT	TEST CONDITION	MIN	TYP.	MAX	UNIT
Current Consumption	I _{CC1}	V _{CC}	—	Stop	—	8	15	mA
	I _{CC2}		—	Forward / Reverse	—	27	50	
	I _{CC3}		—	Brake	—	16	30	
Input Voltage	V _{IL}	DI1 / DI2	—		—	—	0.8	V
	V _{IH}		—		2.0	—	—	
Input Current	I _{IL}	DI1 / DI2	—	V _{IN} = 0.4V	—	—	-100	μA
	I _{IH}		—	V _{IN} = V _{CC}	—	—	100	
Output Saturation Voltage	V _{sat} (total)	M (+) / M (-)	—	I _O = 1.5A, T _c = 25°C	—	2.2	2.9	V
			—	I _O = 1.5A, T _c = 110°C	—	2.2	2.8	
Output Leakage Current	I _{LEAK-U}	M (+) / M (-)	—	V _O = 0V	—	—	-100	μA
	I _{LEAK-L}		—	V _O = V _{CC}	—	—	100	
Diodes Forward Voltage	V _{F-U}	M (+) / M (-)	—	IF = 1.5A	—	2.6	—	V
	V _{F-L}		—		—	1.5	—	
Over-Current Detection	I _{SD}		—		1.8	3	4	A
Shutdown Temperature	T _{SD}		—		—	150	—	°C
Over-Voltage Detection	V _{SD}		—		25	27.5	30	V
Thermal Resistance	R _{θj-c}		—		—	4	—	°C / W
Transfer Delay Time	t _{pLH}		—		—	1	10	μs
	t _{pHL}		—		—	1	10	

Note: The parameter values above are guaranteed in the operating voltage range of 6V to 16V. If the guaranteed range is exceeded in practical use, make sure that the IC operates normally in application.

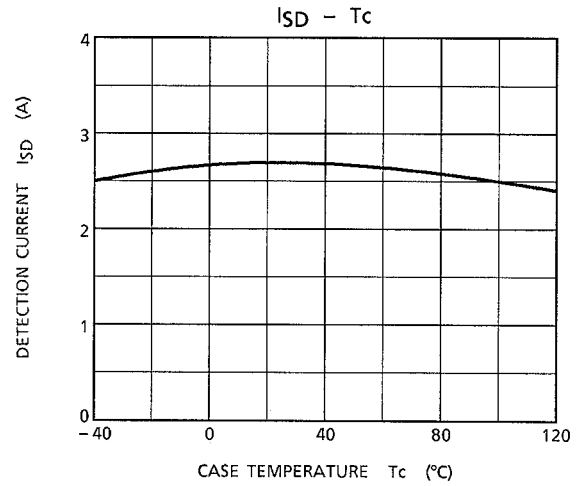
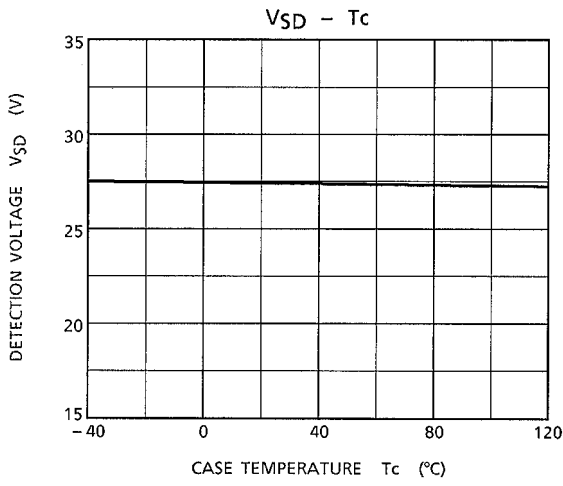
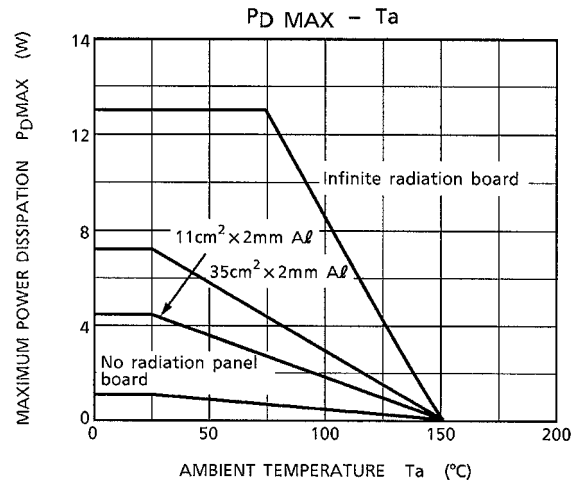
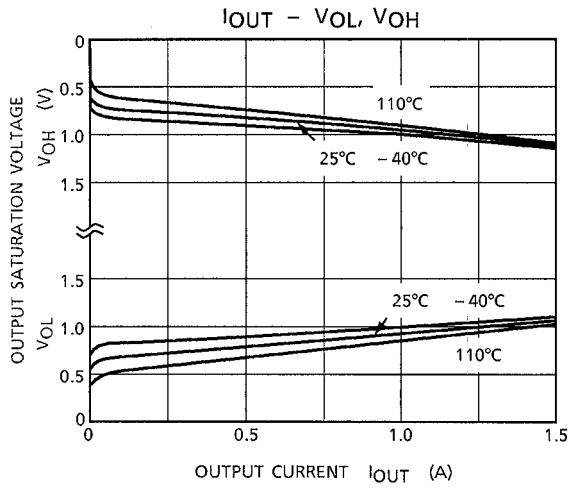

I/O EQUIVALENT CIRCUIT

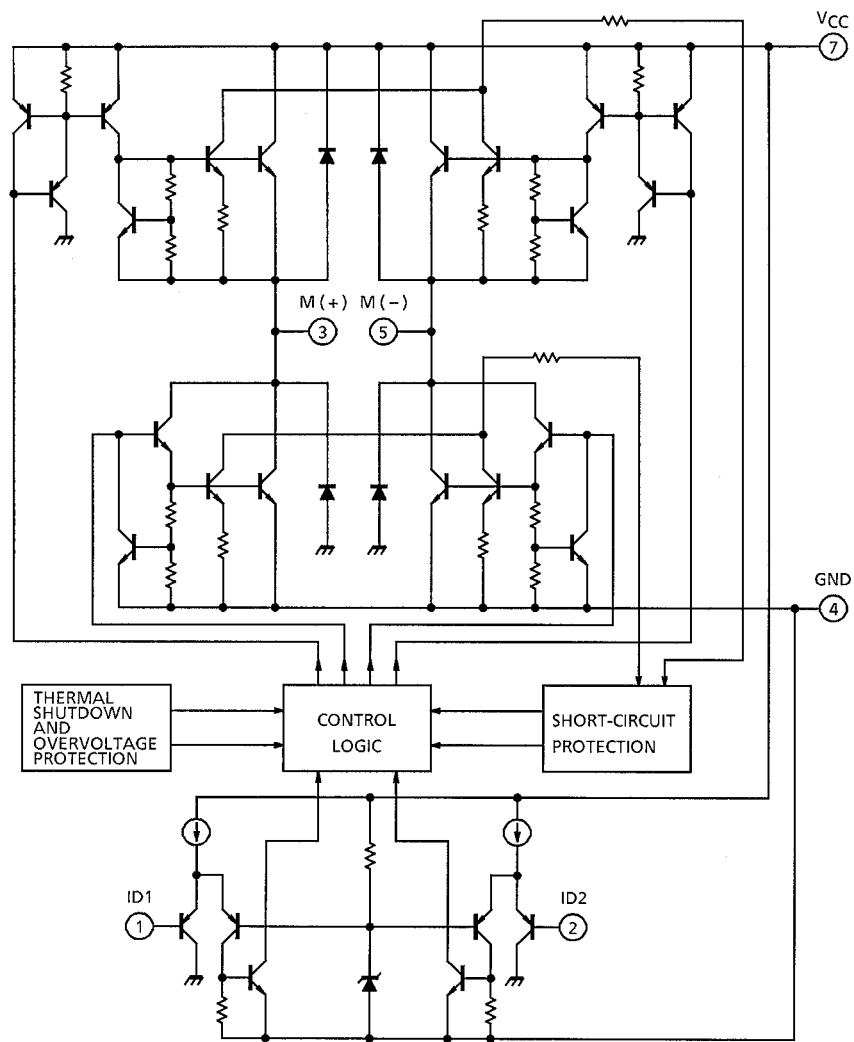

EXAMPLE OF APPLICATION CIRCUIT

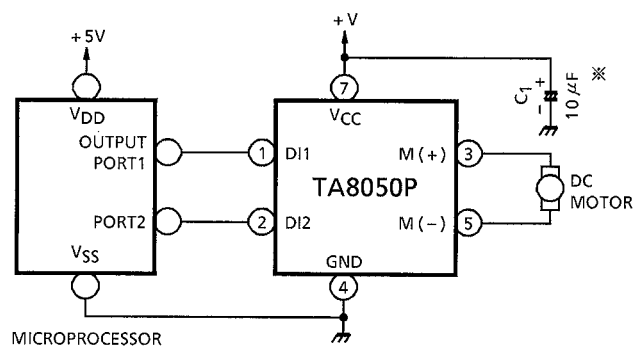

*: Connect this capacitor as close to the IC as possible.

PACKAGE DIMENSIONS

HSIP7-P-2.54

Unit : mm

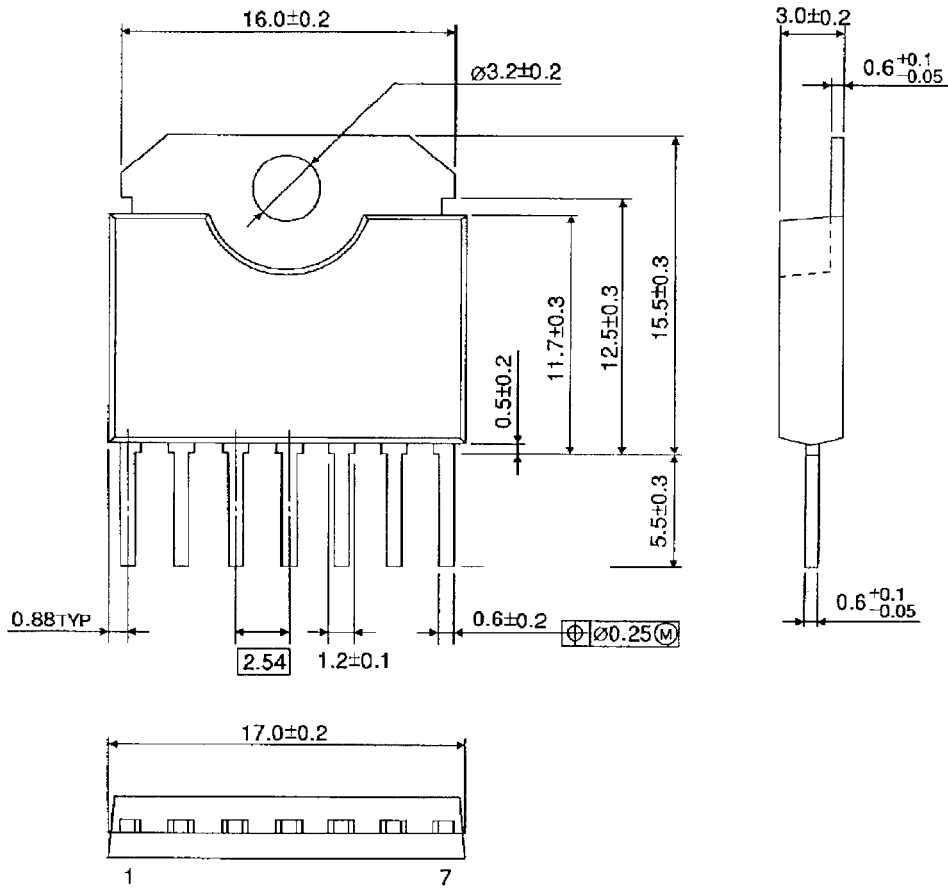

Weight: 1.9g (Typ.)

RESTRICTIONS ON PRODUCT USE

000707EAA_S

- TOSHIBA is continually working to improve the quality and reliability of its products. Nevertheless, semiconductor devices in general can malfunction or fail due to their inherent electrical sensitivity and vulnerability to physical stress. It is the responsibility of the buyer, when utilizing TOSHIBA products, to comply with the standards of safety in making a safe design for the entire system, and to avoid situations in which a malfunction or failure of such TOSHIBA products could cause loss of human life, bodily injury or damage to property.
In developing your designs, please ensure that TOSHIBA products are used within specified operating ranges as set forth in the most recent TOSHIBA products specifications. Also, please keep in mind the precautions and conditions set forth in the "Handling Guide for Semiconductor Devices," or "TOSHIBA Semiconductor Reliability Handbook" etc..
- The information contained herein is presented only as a guide for the applications of our products. No responsibility is assumed by TOSHIBA CORPORATION for any infringements of intellectual property or other rights of the third parties which may result from its use. No license is granted by implication or otherwise under any intellectual property or other rights of TOSHIBA CORPORATION or others.
- The information contained herein is subject to change without notice.

This datasheet has been download from:

www.datasheetcatalog.com

Datasheets for electronics components.